

**NOTES:**

1. CLASS "A" CONCRETE PER SECTION 725.
2. CONSTRUCTION INCLUDING EXPANSION JOINTS AND MAXIMUM SLOPES SHALL CONFORM TO SECTION 340.
3. LIMITS OF ROUGH BROOM FINISH.
4. SUBGRADE PREPARATION PER SECTION 301.
5. SINGLE CURB PER DETAIL 222, TYPE 'B' WHEN REQUIRED BY PLANS. SEE PLANS FOR CURB LENGTHS AND ELEVATIONS.
6. FOR RETROFITS REPLACE CONCRETE TO NEAREST CONTROL JOINT OR AS DIRECTED BY AGENCY.
7. 2" ROLL CURB AND GUTTER PER DETAIL AS SHOWN.
8. CONTROL JOINT.
9. DETAIL 221 CURB AND GUTTER TRANSITION.

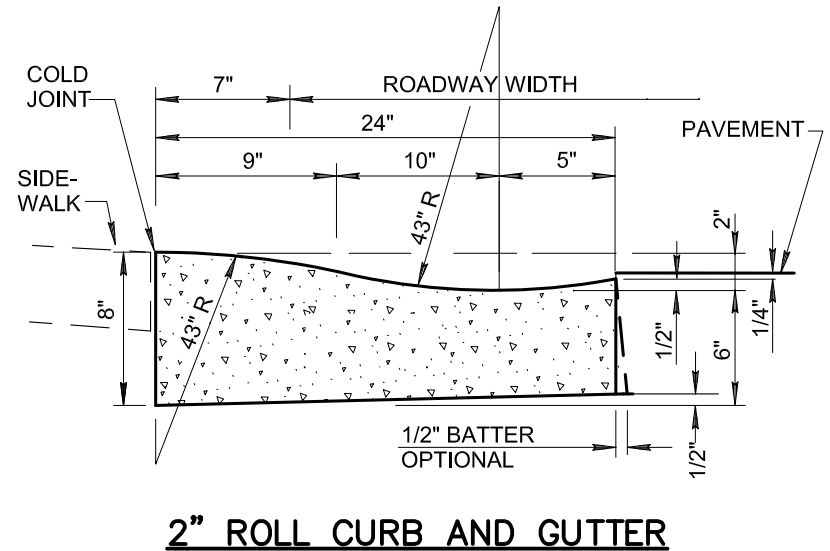

**CURB TRANSITION TO ROLL CURB**

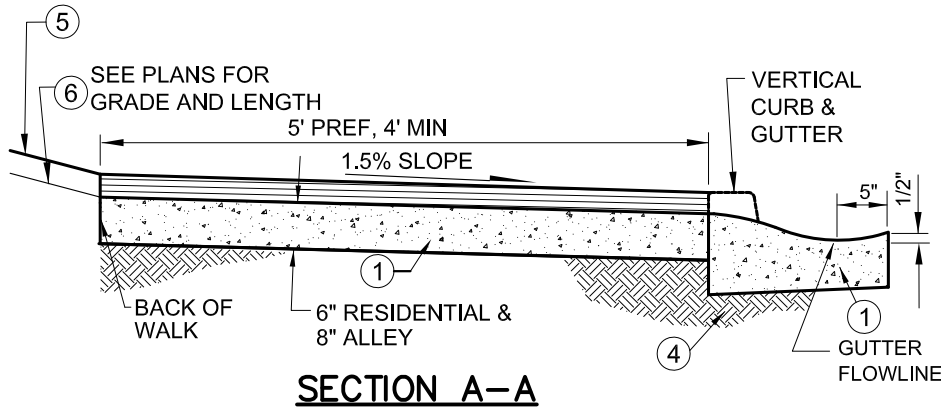
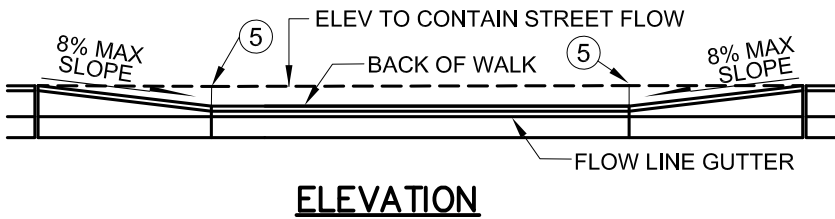
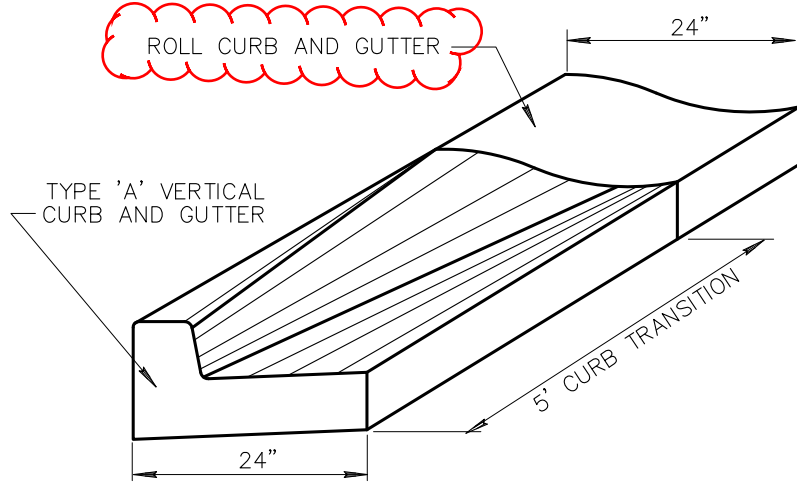

**CURB AND GUTTER TRANSITION**

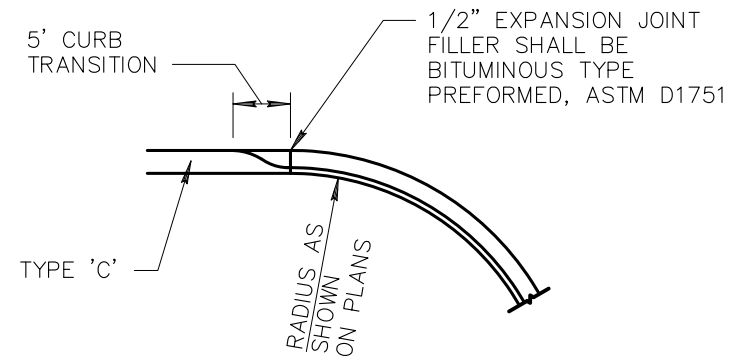

**NOTES: (CURB AND GUTTER TRANSITIONS)**

1. TRANSITIONS WILL BE PAID FOR AS THE PREDOMINANT TYPE OF CURB AND GUTTER BEING TRANSITIONED. WHEN TYPE 'A' CURB AND GUTTER ARE USED AT CURB RETURNS AND TYPE 'C' CURB AND GUTTER IS PREDOMINANTLY USED ELSEWHERE, THE TYPE 'A' TO TYPE 'C' TRANSITION SHALL BE MEASURED AND PAID FOR AS TYPE 'C' CURB AND GUTTER.
2. WHERE PROPOSED CONSTRUCTION IS TO BE CONNECTED TO EXISTING CURB AND GUTTER, THE TRANSITION SHALL BE INDICATED ON PLANS.
3. CLASS 'B' CONCRETE PER SECTION 725.
4. TRANSITION BETWEEN TYPICAL SECTIONS SHALL BE ACCOMPLISHED BY THE USE OF DIRECT STRAIGHT LINE TRANSITIONS OF THE FLOW LINE AND OTHER SURFACE FEATURES.

**INTEGRAL ROLL CURB, GUTTER AND SIDEWALK**

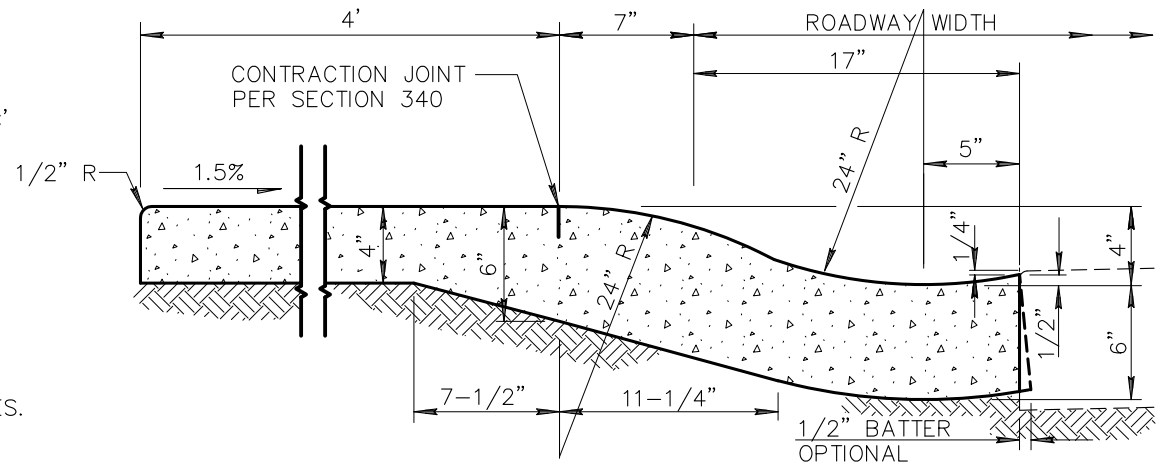

**NOTES: (INTEGRAL ROLL CURB, GUTTER AND SIDEWALK)**

1. CONCRETE TO BE MONOLITHIC POUR. EXPOSED SURFACE FINISH AS PER SIDEWALK AND GUTTER DETAIL.
2. CONTRACTION JOINT SPACING 5' MAXIMUM.
3. EXPANSION JOINTS PER SECTION 340.
4. CLASS 'B' CONCRETE PER SECTION 725.

DETAIL NO.

221



STANDARD DETAIL  
ENGLISH

CURB AND GUTTER TRANSITION AND  
INTEGRAL ROLL CURB, GUTTER AND SIDEWALK

DRAFT

08-17-2017

DETAIL NO.

221