

# Application: GLN-26-SW-001, Glendale FY2026 PM-10 Cert Street Sweeper

## Funding Information

Total Estimated Cost of Sweeper	\$418,551.24
Total Eligible Costs	\$388,047.24
Ineligible Costs	\$30,504.00
Agency Cash Match	\$22,118.69
Total Agency Share of Costs	\$52,622.69
Federal Share of Costs	\$365,928.55

## Sweeper Purpose

Replace a Noncertified Street Sweeper	No
Expand Service Area	Yes
Increase Sweeping Frequency	No
Replace an Older Certified Street Sweeper	Yes

## Roadway Types

Arterial	Yes
Collector	Yes
Residential	Yes
Other	No
Description of Other Lanes	

## Roadway Type Information

Arterial Sweep Cycle Length (measured in days between sweepings)	30
--	----

# Application: GLN-26-SW-001, Glendale FY2026 PM-10 Cert Street Sweeper

## Roadway Type Information

Arterial Lane Miles to be Swept per Cycle	117
Arterial Average Weekday Traffic per Lane Being Swept	3,625
Collector Sweep Cycle Length (measured in days between sweepings)	30
Collector Lane Miles to be Swept per Cycle	84
Collector Average Weekday Traffic per Lane Being Swept	1,250
Residential Sweep Cycle Length (measured in days between sweepings)	30
Residential Lane Miles to be Swept per Cycle	547
Residential Average Weekday Traffic per Lane Being Swept	1,000
Other Sweep Cycle Length (measured in days between sweepings)	
Other Lane Miles to be Swept per Cycle	
Other Average Weekday Traffic per Lane Being Swept	

## Expand Service Areas

Expand Arterial Lane Miles	0
Expand Collector Lane Miles	0
Expand Residential Lane Miles	12
Expand Other Lane Miles	

# Application: GLN-26-SW-001, Glendale FY2026 PM-10 Cert Street Sweeper

## Increase Sweeping Frequency

Previous Arterial Cycle Length	
Previous Collector Cycle Length	
Previous Residential Cycle Length	
Previous Other Cycle Length	

## Replace a PM-10 Certified Street Sweeper

Number of hours in service on the sweeper that is being replaced	7,276
Additional information about hours in service	
The month and year that the older certified sweeper was put into service	January 2017
Additional information about service date	
Number of miles (including deadhead miles) on the sweeper that is being replaced	49,024
Additional information about service miles	
Percent of time older sweeper was out of service	28%
Additional information about out of service percentage	The reasons the sweeper was out of service included repairs to the hydraulic, elevator, fuel, emissions, cooling, and electrical systems.

## Proximity to PM-10 Monitor

Will the requested certified sweeper be used within 4 miles of a PM-10 monitor?	Yes
Names of PM-10 monitors within 4 miles of sweeping route	Glendale

# Application: GLN-26-SW-001, Glendale FY2026 PM-10 Cert Street Sweeper

## Proximity to PM-10 Monitor

## Local Resource Allocation

Have local resources been committed to support the operation of the sweeper?	Yes
Details about local resources	The Field Operations Department, Solid Waste Division, has designated four employees with an Equipment Operator job title to utilize the street sweepers within the City boundaries. Their average annual salary is \$64,771, and their average annual benefits are \$28,477. The average annual O&M is \$48,600.

## Geographical Area

Geographical area that the requested street sweeper will operate	The certified street sweeper will be utilized in and will impact all streets within the City boundaries: residential, collector and arterial.
--	---

## Additional Information

Is the agency willing to provide MAG with additional information?	Yes
Number of Certified Sweepers Operated by Agency	6
Number of Noncertified Sweepers Operated by Agency	0

## Signature

Signature	Michelle Woytenko
Signed Date	9/25/2025 8:55:41 AM
Signed User	mwoytenko@glendaleaz.com, Michelle Woytenko



**Freightliner of Arizona, LLC**

9899 W. Roosevelt St.  
Tolleson, AZ 85353  
Phone: (623) 907-9900

**Buyers Order**

DE-120553  
09/11/2025

Contact: Cory Thompson - Mobile: - Email: cthompson@vvgtruck.com

Bill To: 131050  
CITY OF GLENDALE EQUIPMENT MANAGEMENT  
6210 W MYRTLE STE 111  
GLENDALE AZ 85301-7700  
Phone: (623) 930-2696 FAX: (623) 915-3123  
dhowitt@glendaleaz.com

Ship To:  
CITY OF GLENDALE EQUIPMENT MANAGEMENT  
6210 W MYRTLE STE 111  
GLENDALE AZ 85301-7700

Stock#:	New 2026 FREIGHTLINER M2106 PLUS	Price:	\$148,420.00
VIN: TBD	GVW: 33000		
	XBROOM SWEEPER BODY		
		Unit Price:	\$238,005.00
			\$386,425.00
		<b>Total</b>	<b>\$386,425.00</b>
		State Sales Tax	\$32,098.28
		Arizona Tire Tax	\$27.96
		<b>Total Vehicle Sale Price</b>	<b>\$418,551.24</b>
		Total Deposit :	
		<b>Net Total</b>	<b>\$418,551.24</b>

Lienholder: None.

-C/O AZ STATE CONTRACT #069472  
-QUOTE INCLUDES XBROOM SWEEPER BODY INSTALL AND RED DOT A/C INSTALL

**\*\*\* PRICING IS SUBJECT TO CHANGE DUE TO SUPPLY CHAIN AND PRODUCTION ISSUES. \*\*\***

Legal title to the described vehicle(s) does not pass to purchaser until such time as title to any trade-in is proven to the satisfaction of FREIGHTLINER OF ARIZONA LLC to be unencumbered and purchaser's check or draft, if any, has been verified and cleared. This is to certify that this is a true and correct Bill of Sale.

Dealer: Freightliner of Arizona, LLC (Printed) Customer: CITY OF GLENDALE EQUIPMENT MANAGEMENT (Printed)

By: \_\_\_\_\_ (Signature) By: \_\_\_\_\_ (Signature)

Date \_\_\_\_\_ Date \_\_\_\_\_

SWORN to and SUBSCRIBED before me this \_\_\_\_\_ day of \_\_\_\_\_, \_\_\_\_\_. Notary Public: \_\_\_\_\_

Prepared For :  
Craig Croner  
GLENDALE CITY OF  
6210 W MYRTLE AVE  
GLENDALE, AZ 85301  
UNITED STATES  
Phone :623-930-2621

Prepared by:  
Cory Thompson  
FREIGHTLINER OF ARIZONA  
9899 W ROOSEVELT STREET  
TOLLESON, AZ 85353  
Phone :

*A proposal for*  
**GLENDALE CITY OF**

*Prepared by*  
**FREIGHTLINER OF ARIZONA**

*Cory Thompson*

*September 11, 2025*

**Freightliner M2 106 Plus**

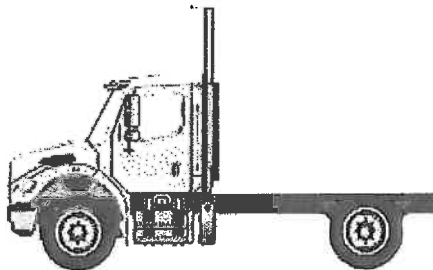

Components shown may not reflect all spec'd options and are not to scale



Prepared For :  
Craig Croner  
GLENDALE CITY OF  
6210 W MYRTLE AVE  
GLENDALE, AZ 85301  
UNITED STATES  
Phone :623-930-2621

Prepared by:  
Cory Thompson  
FREIGHTLINER OF ARIZONA  
9899 W ROOSEVELT STREET  
TOLLESON, AZ 85353  
Phone :

## SPECIFICATION PROPOSAL

Description	Weight Front	Weight Rear
<b>Price Level</b>		
M2 PRL-29M (EFF:MY26 ORDERS)		
<b>Data Version</b>		
SPECPRO21 DATA RELEASE VER 005		
<b>Vehicle Configuration</b>		
M2 106 PLUS CONVENTIONAL CHASSIS	5,709	3,450
2026 MODEL YEAR SPECIFIED		
SET BACK AXLE - TRUCK		
STRAIGHT TRUCK PROVISION, NON-TOWING		
LH PRIMARY STEERING LOCATION AND PREP FOR CUSTOMER SUPPLIED RH SIT-DOWN SECONDARY STEERING LOCATION WITH DUAL INSTRUMENT CLUSTER		
<b>General Service</b>		
TRUCK CONFIGURATION		
DOMICILED, USA 50 STATES (EPA AND CARB CLEAN IDLE LABELS)		
CARB CLEAN IDLE LABELS NOT FOR INITIAL REGISTRATION IN STATES REQUIRING CARB EMISSIONS CERTIFICATION (INCLUDES 6X4 INCH LABELS ON LOWER FORWARD OF DRIVER DOOR)		
UTILITY/REPAIR/MAINTENANCE SERVICE		
UTILITY BUSINESS SEGMENT		
FIXED LOAD COMMODITY		
TERRAIN/DUTY: 100% (ALL) OF THE TIME, IN TRANSIT, IS SPENT ON PAVED ROADS		
MAXIMUM 8% EXPECTED GRADE		
SMOOTH CONCRETE OR ASPHALT PAVEMENT - MOST SEVERE IN-TRANSIT (BETWEEN SITES) ROAD SURFACE		
MEDIUM TRUCK WARRANTY		
EXPECTED FRONT AXLE(S) LOAD 12000.0 lbs		



Prepared For :  
 Craig Croner  
 GLENDALE CITY OF  
 6210 W MYRTLE AVE  
 GLENDALE, AZ 85301  
 UNITED STATES  
 Phone :623-930-2621

Prepared by:  
 Cory Thompson  
 FREIGHTLINER OF ARIZONA  
 9899 W ROOSEVELT STREET  
 TOLLESON, AZ 85353  
 Phone :

Description	Weight Front	Weight Rear
EXPECTED REAR DRIVE AXLE(S) LOAD 21000.0 lbs		
EXPECTED GROSS VEHICLE WEIGHT CAPACITY 33000.0 lbs		
<b>Truck Service</b>		
STREET SWEEPER BODY		
NESCO		
EXPECTED BODY/PAYLOAD CG HEIGHT ABOVE FRAME "XX" INCHES 32.0 in		
<b>Engine</b>		
CUM L9 300 HP @ 2200 RPM; 2200 GOV RPM, 860 LB-FT @ 1200 RPM	640	30
<b>Electronic Parameters</b>		
75 MPH ROAD SPEED LIMIT		
CRUISE CONTROL SPEED LIMIT SAME AS ROAD SPEED LIMIT		
PTO MODE ENGINE RPM LIMIT - 1250 RPM		
PTO MODE THROTTLE OVERRIDE - LIMIT TO 1500 RPM		
PTO ENGINE SPEED CONTROL DEACTIVATED BY SERVICE BRAKE LIGHTLY APPLIED (STATIONARY APPLICATIONS)		
PTO RPM WITH CRUISE SET SWITCH - 800 RPM		
PTO RPM WITH CRUISE RESUME SWITCH - 800 RPM		
PTO MODE CANCEL VEHICLE SPEED - 30 MPH		
PTO GOVERNOR RAMP RATE - 250 RPM PER SECOND		
CRUISE CONTROL BUTTON PTO CONTROL AND ONE REMOTE PTO SPEED		
PTO SPEED 1 SETTING - 1200 RPM		
NO FLEET SPEC FOR PARAMETERIZATION		
PTO MINIMUM RPM - 800		
REGEN INHIBIT SPEED THRESHOLD - 5 MPH		



Prepared For :  
 Craig Croner  
 GLENDALE CITY OF  
 6210 W MYRTLE AVE  
 GLENDALE, AZ 85301  
 UNITED STATES  
 Phone :623-930-2621

Prepared by:  
 Cory Thompson  
 FREIGHTLINER OF ARIZONA  
 9899 W ROOSEVELT STREET  
 TOLLESON, AZ 85353  
 Phone :

Description	Weight Front	Weight Rear
<b>Engine Equipment</b>		
PTO 1, WITH SWITCH, TEM SUPPLIED REQUEST AND INTERLOCKS, WITH PTO CONNECTIONS, ENGAGE BEFORE DRIVING INTERLOCKS		
EPA 2010 GHG 2024/CARB 2024 ULTRALOW NOX CONFIGURATION		
STANDARD OIL PAN		
ENGINE MOUNTED OIL CHECK AND FILL		
SIDE OF HOOD AIR INTAKE WITH FIREWALL MOUNTED DONALDSON AIR CLEANER		
DR 12V 160 AMP 28-SI QUADRAMOUNT PAD ALTERNATOR WITH REMOTE BATTERY VOLT SENSE		
(2) DTNA GENUINE, FLOODED STARTING, MIN 2000CCA, 370RC, THREADED STUD BATTERIES	10	
BATTERY BOX FRAME MOUNTED		
STANDARD BATTERY JUMPERS		
SINGLE BATTERY BOX FRAME MOUNTED LH SIDE UNDER CAB		
WIRE GROUND RETURN FOR BATTERY CABLES WITH ADDITIONAL FRAME GROUND RETURN		
NON-POLISHED BATTERY BOX COVER		
NON-ESSENTIAL POSITIVE LOAD DISCONNECT, IN CAB CONTROL SWITCH MOUNTED OUTBOARD OF DRIVER SEAT	2	
POSITIVE AND NEGATIVE POSTS FOR JUMPSTART LOCATED ON FRAME NEXT TO STARTER	2	
PROGRESSIVE LOW VOLTAGE DISCONNECT AT 12.3 VOLTS FOR DESIGNATED CIRCUITS	2	
CUMMINS TURBOCHARGED 18.7 CFM AIR COMPRESSOR WITH INTERNAL SAFETY VALVE		
STANDARD MECHANICAL AIR COMPRESSOR GOVERNOR		
AIR COMPRESSOR DISCHARGE LINE		
ELECTRONIC ENGINE INTEGRAL SHUTDOWN PROTECTION SYSTEM		
CUMMINS ENGINE INTEGRAL BRAKE WITH VARIABLE GEOMETRY TURBO ON/OFF WITH BRAKE LAMPS	20	
RH OUTBOARD UNDER STEP MOUNTED HORIZONTAL AFTERTREATMENT SYSTEM ASSEMBLY WITH RH B-	30	25



Prepared For :  
 Craig Croner  
 GLENDALE CITY OF  
 6210 W MYRTLE AVE  
 GLENDALE, AZ 85301  
 UNITED STATES  
 Phone :623-930-2621

Prepared by:  
 Cory Thompson  
 FREIGHTLINER OF ARIZONA  
 9899 W ROOSEVELT STREET  
 TOLLESON, AZ 85353  
 Phone :

Description	Weight Front	Weight Rear
PILLAR MOUNTED VERTICAL TAILPIPE		
ENGINE AFTERTREATMENT DEVICE, AUTOMATIC OVER THE ROAD ACTIVE REGENERATION AND VIRTUAL REGENERATION REQUEST SWITCH IN CLUSTER AND DASH MOUNTED INHIBIT SWITCH		
10 FOOT 00 INCH (120 INCH+0/-5.9 INCH) EXHAUST SYSTEM HEIGHT		
RH CURVED VERTICAL TAILPIPE B-PILLAR MOUNTED ROUTED FROM STEP		
6 GALLON DIESEL EXHAUST FLUID TANK		
100 PERCENT DIESEL EXHAUST FLUID FILL		
LH MEDIUM DUTY STANDARD DIESEL EXHAUST FLUID TANK LOCATION		
STANDARD DIESEL EXHAUST FLUID PUMP MOUNTING		
STANDARD DIESEL EXHAUST FLUID TANK CAP		
ALUMINUM AFTERTREATMENT DEVICE/MUFFLER/TAILPIPE SHIELD(S)		
AIR POWERED ON/OFF ENGINE FAN CLUTCH		
AUTOMATIC FAN CONTROL WITHOUT DASH SWITCH, NON ENGINE MOUNTED		
CUMMINS SPIN ON FUEL FILTER		
COMBINATION FULL FLOW/BYPASS OIL FILTER		
NO COOLANT FILTER	-10	
900 SQUARE INCH ALUMINUM RADIATOR	15	
ANTIFREEZE TO -34F, OAT (NITRITE AND SILICATE FREE) EXTENDED LIFE COOLANT		
GATES BLUE STRIPE COOLANT HOSES OR EQUIVALENT		
CONSTANT TENSION HOSE CLAMPS FOR COOLANT HOSES		
RADIATOR DRAIN VALVE		
LOWER RADIATOR GUARD		
PHILLIPS-TEMRO 1000 WATT/115 VOLT BLOCK HEATER	4	



Prepared for:  
 Craig Croner  
 GLENDALE CITY OF  
 6210 W MYRTLE AVE  
 GLENDALE, AZ 85301  
 UNITED STATES  
 Phone :623-930-2621

Prepared by:  
 Cory Thompson  
 FREIGHTLINER OF ARIZONA  
 9899 W ROOSEVELT STREET  
 TOLLESON, AZ 85353  
 Phone :

Description	Weight Front	Weight Rear
CHROME ENGINE HEATER RECEPTACLE MOUNTED UNDER LH DOOR		
ALUMINUM FLYWHEEL HOUSING		
ELECTRIC GRID AIR INTAKE WARMER		
DELCO 12V 39MT HD/OCP STARTER WITH THERMAL PROTECTION AND INTEGRATED MAGNETIC SWITCH	15	
<b>Transmission</b>		
ALLISON 3500 RDS AUTOMATIC TRANSMISSION WITH PTO PROVISION	200	60

**Transmission Equipment**

ALLISON VOCATIONAL PACKAGE 169 - AVAILABLE ON 3000/4000 PRODUCT FAMILIES WITH VOCATIONAL MODEL RDS

ALLISON VOCATIONAL RATING FOR ON/OFF HIGHWAY APPLICATIONS AVAILABLE WITH ALL PRODUCT FAMILIES

PRIMARY MODE GEARS, LOWEST GEAR 1, START GEAR 1, HIGHEST GEAR 6, AVAILABLE FOR 3000/4000 PRODUCT FAMILIES ONLY

SECONDARY MODE GEARS, LOWEST GEAR 1, START GEAR 1, HIGHEST GEAR 6, AVAILABLE FOR 3000/4000 PRODUCT FAMILIES ONLY

PRIMARY SHIFT SCHEDULE RECOMMENDED BY DTNA AND ALLISON, THIS DEFINED BY ENGINE AND VOCATIONAL USAGE

SECONDARY SHIFT SCHEDULE RECOMMENDED BY DTNA AND ALLISON, THIS DEFINED BY ENGINE AND VOCATIONAL USAGE

PRIMARY SHIFT SPEED RECOMMENDED BY DTNA AND ALLISON, THIS DEFINED BY ENGINE AND VOCATIONAL USAGE

SECONDARY SHIFT SPEED RECOMMENDED BY DTNA AND ALLISON, THIS DEFINED BY ENGINE AND VOCATIONAL USAGE

ENGINE BRAKE RANGE PRESELECT RECOMMENDED BY DTNA AND ALLISON, THIS DEFINED BY ENGINE AND VOCATIONAL USAGE

ENGINE BRAKE RANGE ALTERNATE PRESELECT RECOMMENDED BY DTNA AND ALLISON, THIS DEFINED BY ENGINE AND VOCATIONAL USAGE

FUEL SENSE 2.0 PLUS - DYNACTIVE: PERFORMANCE, NEUTRAL AT STOP: ACTIVE

DRIVER SWITCH INPUT - DEFAULT - NO SWITCHES



Prepared For :  
 Craig Croner  
 GLENDALE CITY OF  
 6210 W MYRTLE AVE  
 GLENDALE, AZ 85301  
 UNITED STATES  
 Phone :623-930-2621

Prepared by:  
 Cory Thompson  
 FREIGHTLINER OF ARIZONA  
 9899 W ROOSEVELT STREET  
 TOLLESON, AZ 85353  
 Phone :

Description	Weight Front	Weight Rear
DIRECTION CHANGE ENABLED WITH MULTIPLEXED SERVICE BRAKES - ALLISON 5TH GEN TRANSMISSIONS		
QUICKFIT BODY LIGHTING CONNECTOR UNDER CAB, WITH BLUNTCUTS		
ELECTRONIC TRANSMISSION WIRING TO CUSTOMER INTERFACE CONNECTOR		
CHELSEA PTO - CHL281GMFJP B5XD	50	
PTO MOUNTING, LH SIDE OF MAIN TRANSMISSION ALLISON		
MAGNETIC PLUGS, ENGINE DRAIN, TRANSMISSION DRAIN, AXLE(S) FILL AND DRAIN		
PUSH BUTTON ELECTRONIC SHIFT CONTROL, DASH MOUNTED		
TRANSMISSION PROGNOSTICS - ENABLED 2013		
WATER TO OIL TRANSMISSION COOLER, IN RADIATOR END TANK	15	
TRANSMISSION OIL CHECK AND FILL WITH ELECTRONIC OIL LEVEL CHECK		
ATF-SYNTHETIC AUTOMATIC TRANSMISSION FLUID		

**Front Axle and Equipment**

DETROIT DA-F-12.0-3 12,000# FF1 71.5 KPI/3.74 DROP SINGLE FRONT AXLE

MERITOR 15X4 Q+ CAM FRONT BRAKES

NON-ASBESTOS FRONT BRAKE LINING

CONMET CAST IRON FRONT BRAKE DRUMS

FRONT OIL SEALS

VENTED FRONT HUB CAPS WITH WINDOW, CENTER AND SIDE PLUGS - OIL

STANDARD SPINDLE NUTS FOR ALL AXLES

MERITOR AUTOMATIC FRONT SLACK ADJUSTERS

TRW THP-60 POWER STEERING

POWER STEERING PUMP

2 QUART SEE THROUGH POWER STEERING RESERVOIR



Prepared For :  
 Craig Croner  
 GLENDALE CITY OF  
 6210 W MYRTLE AVE  
 GLENDALE, AZ 85301  
 UNITED STATES  
 Phone :623-930-2621

Prepared by:  
 Cory Thompson  
 FREIGHTLINER OF ARIZONA  
 9899 W ROOSEVELT STREET  
 TOLLESON, AZ 85353  
 Phone :

Description	Weight Front	Weight Rear
<b>Front Suspension</b>		
GUARANTEED NAME BRAND "ROADRANGER SYNTHETIC" FE 75W-90 FRONT AXLE LUBE		
12,000# DUAL TAPERLEAF FRONT SUSPENSION	42	
MAINTENANCE FREE RUBBER BUSHINGS - FRONT SUSPENSION		
FRONT SUSPENSION WITH LEFT HAND OFFSET SHACKLE BRACKET	4	
FRONT SHOCK ABSORBERS		
<b>Rear Axle and Equipment</b>		
MERITOR RS-23-160 23,000# R-SERIES SINGLE REAR AXLE		180
5.38 REAR AXLE RATIO		
IRON REAR AXLE CARRIER WITH STANDARD AXLE HOUSING		
RPL14 MERITOR SERVICE-FREE MAIN DRIVELINE WITH HALF ROUND (17T) YOKES	-20	-20
MERITOR 16.5X7 Q+ CAST SPIDER CAM REAR BRAKES, DOUBLE ANCHOR, FABRICATED SHOES		
NON-ASBESTOS REAR BRAKE LINING		
BRAKE CAMS AND CHAMBERS ON FORWARD SIDE OF DRIVE AXLE(S) WITH AUXILIARY SUPPORT BRACKETS		
CONMET CAST IRON REAR BRAKE DRUMS		
REAR BRAKE DUST SHIELDS		5
REAR OIL SEALS		
WABCO TRISTOP D LONGSTROKE 1-DRIVE AXLE SPRING PARKING CHAMBERS		
HALDEX AUTOMATIC REAR SLACK ADJUSTERS		
GUARANTEED NAME BRAND "ROADRANGER SYNTHETIC" FE 75W-90 REAR AXLE LUBE		
<b>Rear Suspension</b>		
AIRLINER 21,000# REAR SUSPENSION		
AIRLINER HIGH POSITION RIDE HEIGHT		
STANDARD AXLE SEATS IN AXLE CLAMP GROUP		



Prepared For :  
 Craig Croner  
 GLENDALE CITY OF  
 6210 W MYRTLE AVE  
 GLENDALE, AZ 85301  
 UNITED STATES  
 Phone :623-930-2621

Prepared by:  
 Cory Thompson  
 FREIGHTLINER OF ARIZONA  
 9899 W ROOSEVELT STREET  
 TOLLESON, AZ 85353  
 Phone :

Description	Weight Front	Weight Rear
IGNITION CONTROLLED ELECTRIC DUMP SWITCH FOR AIR SUSPENSION WITH STATE RETENTION AND GAUGE		
REAR AIR SUSPENSION DUMP VALVE AUTOFILL >5 MPH WITH INDICATOR LIGHT		
SINGLE AIR REAR SUSPENSION LEVELING VALVE		
TRANSVERSE CONTROL RODS		
REAR SHOCK ABSORBERS - ONE AXLE (AIR RIDE SUSPENSION)		
<b>Pusher / Tag Equipment</b>		
NO PUSHER/TAG BRAKE DUST SHIELDS		
<b>Brake System</b>		
AIR BRAKE PACKAGE		
WABCO 4S/4M ABS WITH TRACTION CONTROL		
REINFORCED NYLON, FABRIC BRAID AND WIRE BRAID CHASSIS AIR LINES		
FIBER BRAID PARKING BRAKE HOSE		
STANDARD BRAKE SYSTEM VALVES		
STANDARD AIR SYSTEM PRESSURE PROTECTION SYSTEM		
STD U.S. FRONT BRAKE VALVE		
RELAY VALVE WITH 5-8 PSI CRACK PRESSURE, NO REAR PROPORTIONING VALVE		
BW AD-9 BRAKE LINE AIR DRYER WITH HEATER	20	
AIR DRYER FRAME MOUNTED		
STEEL AIR TANKS MOUNTED AFT INSIDE AND/OR BELOW FRAME JUST FORWARD OF REAR SUSPENSION		
PULL CABLE ON WET TANK, PETCOCK DRAIN VALVES ON ALL OTHER AIR TANKS		

**Trailer Connections**

- NO TRAILER AIR HOSE
- NO AIR HOSE HANGER
- NO TRAILER ELECTRICAL CABLE



Prepared For :  
 Craig Croner  
 GLENDALE CITY OF  
 8210 W MYRTLE AVE  
 GLENDALE, AZ 85301  
 UNITED STATES  
 Phone :623-930-2621

Prepared by:  
 Cory Thompson  
 FREIGHTLINER OF ARIZONA  
 9899 W ROOSEVELT STREET  
 TOLLESON, AZ 85353  
 Phone :

Description	Weight Front	Weight Rear
<b>Wheelbase &amp; Frame</b>		
3550MM (140 INCH) WHEELBASE		
7/16X3-9/16X11-1/8 INCH STEEL FRAME (11.11MMX282.6MM/0.437X11.13 INCH) 120KSI	-190	320
512MM (20.16 INCH) REAR FRAME OVERHANG		
CUSTOM FRAME OVERHANG RANGE		
CALC'D BACK OF CAB TO REAR SUSP C/L (CA) 74.21 in		
CALCULATED EFFECTIVE BACK OF CAB TO REAR SUSPENSION C/L (CA) 71.21 in		
CALC'D FRAME LENGTH - OVERALL -9819.26 in		
CALCULATED FRAME SPACE LH SIDE 40.5 in		
CALCULATED FRAME SPACE RH SIDE 42.59 in		
CALC'D SPACE AVAILABLE FOR DECKPLATE 0.0 in		
FLANGED TAPERED 60 DEGREE ANGLE END OF FRAME		
FRONT CLOSING CROSSMEMBER		
STANDARD WEIGHT ENGINE CROSSMEMBER		
STANDARD CROSSMEMBER BACK OF TRANSMISSION		
STANDARD MIDSHIP #1 CROSSMEMBER(S)		
STANDARD REARMOST CROSSMEMBER		
STANDARD SUSPENSION CROSSMEMBER		

**Chassis Equipment**

THREE-PIECE 14 INCH CHROMED STEEL BUMPER WITH COLLAPSIBLE ENDS	30
FRONT TOW HOOKS - FRAME MOUNTED	15
BUMPER MOUNTING FOR SINGLE LICENSE PLATE	
NO MUDFLAP BRACKETS	
NO REAR MUDFLAPS	



Prepared For :  
 Craig Croner  
 GLENDALE CITY OF  
 6210 W MYRTLE AVE  
 GLENDALE, AZ 85301  
 UNITED STATES  
 Phone :623-930-2621

Prepared by:  
 Cory Thompson  
 FREIGHTLINER OF ARIZONA  
 9899 W ROOSEVELT STREET  
 TOLLESON, AZ 85353  
 Phone :

Description	Weight Front	Weight Rear
FENDER AND FRONT OF HOOD MOUNTED FRONT MUDFLAPS		
GRADE 8 THREADED HEX HEADED FRAME FASTENERS		
EXTERIOR HARNESSSES WRAPPED IN ABRASION TAPE		
D15-28195-000 CENTER PUNCH TO MARK CENTERLINE OF REAR SUSPENSION ON TOP FLANGE OF FRAME		
DRLG PREP FOR NESCON,M2106FRMH, REV -, 1/18/2022		
CLEAR FRAME RAIL FROM BACK OF CAB TO FRONT REAR SUSPENSION BRACKET LH RAIL INSIDE/OUTBOARD AND BELOW		
<b>Fifth Wheel</b>		
NO FIFTH WHEEL		
<b>Fuel Tanks</b>		
50 GALLON/189 LITER SHORT RECTANGULAR ALUMINUM FUEL TANK - LH	20	
RECTANGULAR FUEL TANK(S)		
PLAIN ALUMINUM/PAINTED STEEL FUEL/HYDRAULIC TANK(S) WITH PAINTED BANDS		
FUEL TANK(S) FORWARD		
POLISHED STAINLESS STEEL STEP FINISH		
FUEL TANK CAP(S)		
DETROIT FUEL/WATER SEPARATOR WITH WATER IN FUEL SENSOR	-5	
EQUIFLO INBOARD FUEL SYSTEM		
HIGH TEMPERATURE REINFORCED NYLON FUEL LINE		
<b>Tires</b>		
BRIDGESTONE ECOPIA R268 11R22.5 14 PLY RADIAL FRONT TIRES	12	
BRIDGESTONE ECOPIA R268 11R22.5 14 PLY RADIAL REAR TIRES		24
<b>Hubs</b>		
CONMET PRESET PLUS PREMIUM IRON FRONT HUBS		



Prepared For :  
 Craig Croner  
 GLENDALE CITY OF  
 6210 W MYRTLE AVE  
 GLENDALE, AZ 85301  
 UNITED STATES  
 Phone :623-930-2621

Prepared by:  
 Cory Thompson  
 FREIGHTLINER OF ARIZONA  
 9899 W ROOSEVELT STREET  
 TOLLESON, AZ 85353  
 Phone :

Description	Weight Front	Weight Rear
CONMET PRESET PLUS PREMIUM IRON REAR HUBS		
<b>Wheels</b>		
F/L BEVEL LOGO 40620 22.5X8.25 10-HUB PILOT 5.72 INSET ALUMINUM DISC FRONT WHEELS	-46	
F/L BEVEL LOGO 40620 22.5X8.25 10-HUB PILOT 5.72 INSET ALUMINUM DISC REAR WHEELS		-92
FRONT WHEEL MOUNTING NUTS		
REAR WHEEL MOUNTING NUTS		
<b>Cab Exterior</b>		
106 INCH BBC FLAT ROOF ALUMINUM CONVENTIONAL CAB		
LEAF SPRING REAR CAB SUSPENSION		
LH AND RH GRAB HANDLES		
MOLD-IN COLOR GRILLE		
MOLD-IN COLOR HOOD MOUNTED AIR INTAKE GRILLE		
FIBERGLASS HOOD		
FREIGHTLINER NAME PLATES		
TUNNEL/FIREWALL LINER		
SINGLE 14 INCH ROUND HADLEY AIR HORN UNDER LH DECK	4	
SINGLE ELECTRIC HORN		
REAR LICENSE PLATE MOUNT END OF FRAME		
LED HEADLIGHT ASSEMBLY AND INCANDESCENT MARKER/TURN LAMP WITH CHROME BEZEL		
LED AERODYNAMIC MARKER LIGHTS		
NO DAYTIME RUNNING LIGHTS		
OMIT STOP/TAIL/BACKUP LIGHTS AND PROVIDE WIRING WITH SEPARATE STOP/TAIL WIRES TO 17 FEET BEYOND END OF FRAME		
STANDARD FRONT TURN SIGNAL LAMPS		



Prepared For :  
 Craig Croner  
 GLENDALE CITY OF  
 6210 W MYRTLE AVE  
 GLENDALE, AZ 85301  
 UNITED STATES  
 Phone :623-930-2621

Prepared by:  
 Cory Thompson  
 FREIGHTLINER OF ARIZONA  
 9899 W ROOSEVELT STREET  
 TOLLESON, AZ 85353  
 Phone :

Description	Weight Front	Weight Rear
DUAL WEST COAST BRIGHT FINISH HEATED MIRRORS WITH LH AND RH REMOTE		
DOOR MOUNTED MIRRORS		
102 INCH EQUIPMENT WIDTH		
LH AND RH 8 INCH BRIGHT FINISH CONVEX MIRRORS MOUNTED UNDER PRIMARY MIRRORS		
RH AND LH 8 INCH STAINLESS STEEL FENDER MOUNTED CONVEX MIRRORS WITH TRIPOD BRACKETS	8	
STANDARD SIDE/REAR REFLECTORS		
RH AFTERTREATMENT SYSTEM CAB ACCESS WITH POLISHED DIAMOND PLATE COVER		
COMPOSITE EXTERIOR SUN VISOR	10	
63X14 INCH TINTED REAR WINDOW		
TINTED DOOR GLASS LH AND RH WITH TINTED NON-OPERATING WING WINDOWS		
RH AND LH ELECTRIC POWERED WINDOWS		
1-PIECE SOLAR GREEN GLASS WINDSHIELD		
2 GALLON WINDSHIELD WASHER RESERVOIR WITH FLUID LEVEL INDICATOR, FRAME MOUNTED		
<b>Cab Interior</b>		
RUGGED TRIM PACKAGE		
GRAY & CARBON VINYL INTERIOR "RUGGED"		
CARBON WITH PREMIUM GUNMETAL ACCENT (RUGGED)		
MOLDED DOOR PANEL		
MOLDED PLASTIC DOOR PANEL		
BLACK MATS WITH SINGLE INSULATION		
(1)DASH MOUNTED 12V POWER OUTLET, (1)DASH MOUNTED DUAL USB-C OUTLET		
FORWARD ROOF MOUNTED CONSOLE		
LH AND RH DOOR STORAGE POCKETS INTEGRATED INTO MOLDED DOOR PANELS		



Prepared For :  
 Craig Crone  
 GLENDALE CITY OF  
 6210 W MYRTLE AVE  
 GLENDALE, AZ 85301  
 UNITED STATES  
 Phone :623-930-2621

Prepared by:  
 Cory Thompson  
 FREIGHTLINER OF ARIZONA  
 9899 W ROOSEVELT STREET  
 TOLLESON, AZ 85353  
 Phone :

Description	Weight Front	Weight Rear
DIGITAL ALARM CLOCK IN DRIVER DISPLAY		
(2) CUP HOLDERS LH AND RH DASH		
M2/SD DASH		
2-1/2 LB. FIRE EXTINGUISHER	5	
HEATER, DEFROSTER AND AIR CONDITIONER		
STANDARD HVAC DUCTING		
MAIN HVAC CONTROLS WITH RECIRCULATION SWITCH		
STANDARD HEATER PLUMBING		
VALEO HEAVY DUTY A/C REFRIGERANT COMPRESSOR		
BINARY CONTROL, R-134A		
STANDARD INSULATION		
SOLID-STATE CIRCUIT PROTECTION AND FUSES		
12V NEGATIVE GROUND ELECTRICAL SYSTEM		
STANDARD LED CAB LIGHTING		
NO SECURITY DEVICE		
DOOR LOCKS AND IGNITION SWITCH KEYED THE SAME		
KEY QUANTITY OF 2		
LH AND RH ELECTRIC DOOR LOCKS		
NO MATTRESS	-20	-15
TRIANGULAR REFLECTORS WITHOUT FLARES	10	
BASIC ISRINGHAUSEN HIGH BACK AIR SUSPENSION DRIVERS SEAT WITH MECHANICAL LUMBAR AND INTEGRATED CUSHION EXTENSION	30	
BASIC ISRINGHAUSEN HIGH BACK AIR SUSPENSION PASSENGER SEAT WITH MECHANICAL LUMBAR AND INTEGRATED CUSHION EXTENSION	25	10
DUAL DRIVER AND PASSENGER SEAT ARMRESTS	8	



Prepared For :  
Craig Croner  
GLENDALE CITY OF  
6210 W MYRTLE AVE  
GLENDALE, AZ 85301  
UNITED STATES  
Phone :623-930-2621

Prepared by:  
Cory Thompson  
FREIGHTLINER OF ARIZONA  
9899 W ROOSEVELT STREET  
TOLLESON, AZ 85353  
Phone :

Description	Weight Front	Weight Rear
LH AND RH INTEGRAL DOOR PANEL ARMRESTS		
NO SEAT OPTIONS		
BLACK CORDURA PLUS CLOTH DRIVER SEAT COVER		
BLACK CORDURA PLUS CLOTH PASSENGER SEAT COVER		
BLACK SEAT BELTS		
FIXED STEERING COLUMN		
4-SPOKE 18 INCH (450MM) LEATHER WRAPPED STEERING WHEEL WITH CHROME SWITCH BEZELS		
DRIVER AND PASSENGER INTERIOR SUN VISORS		

#### Instruments & Controls

4 EXTRA PROGRAMMABLE SWITCHES/INDICATORS

ELECTRONIC ACCELERATOR CONTROL

NO INSTRUMENT PANEL-DRIVER

FULLY CONFIGURABLE CENTER INSTRUMENT PANELS

ENGINE REMOTE INTERFACE WITH PARK BRAKE INTERLOCK

BRIGHT ARGENT FINISH GAUGE BEZELS

LOW AIR PRESSURE INDICATOR LIGHT AND AUDIBLE ALARM

(1) PNEUMATIC SINGLE BRAKE APPLICATION AIR GAUGE

DUAL NEEDLE PRIMARY AND SECONDARY AIR PRESSURE GAUGE

ELECTRONIC AIR RESTRICTION INDICATOR DISPLAYED IN DRIVER DISPLAY

87 DB TO 112 DB SELF-ADJUSTING BACKUP ALARM TEMPORARILY MOUNTED END OF FRAME WITH ADDITIONAL 10 FEET OF WIRE

ELECTRONIC CRUISE CONTROL WITH CONTROLS ON STEERING WHEEL SPOKES

KEY OPERATED IGNITION SWITCH AND INTEGRAL START POSITION; 4 POSITION  
OFF/RUN/START/ACCESSORY



Prepared For :  
 Craig Croner  
 GLENDALE CITY OF  
 6210 W MYRTLE AVE  
 GLENDALE, AZ 85301  
 UNITED STATES  
 Phone :623-930-2621

Prepared by:  
 Cory Thompson  
 FREIGHTLINER OF ARIZONA  
 9899 W ROOSEVELT STREET  
 TOLLESON, AZ 85353  
 Phone :

Description	Weight Front	Weight Rear
PREMIUM INSTRUMENT CLUSTER WITH 5.0 INCH TFT COLOR DISPLAY		
DIGITAL PANEL LAMP DIMMER SWITCH IN DRIVER DISPLAY		
HEAVY DUTY ONBOARD DIAGNOSTICS INTERFACE CONNECTOR LOCATED BELOW LH DASH		
2 INCH ELECTRIC FUEL GAUGE		
ENGINE REMOTE INTERFACE WITH ONE OR MORE SET SPEEDS		
QUICKFIT POWERTRAIN INTERFACE CONNECTOR UNDER CAB WITH BLUNTCUTS		
QUICKFIT PROGRAMMABLE INTERFACE CONNECTOR(S) UNDER CAB WITH BLUNTCUTS		
ENGINE REMOTE INTERFACE CONNECTOR AT POWERTRAIN INTERFACE CONNECTOR		
ELECTRICAL ENGINE COOLANT TEMPERATURE GAUGE		
DIGITAL TRANSMISSION OIL TEMPERATURE IN DRIVER DISPLAY		
ELECTRONIC OUTSIDE TEMPERATURE SENSOR DISPLAY IN DRIVER MESSAGE CENTER		
ENGINE AND TRIP HOUR METERS INTEGRAL WITHIN DRIVER DISPLAY		
PTO CONTROLS FOR ENHANCED VEHICLE ELECTRIC/ELECTRONIC ARCHITECTURE		
NO OBSTACLE DETECTION SYSTEM		
NO DR ASSIST SYSTEM		
NO CAMERA/VIDEO/IMAGING SYSTEM		
NO VEHICLE STABILITY ADVISOR OR CONTROL		
NO LANE DEPARTURE WARNING SYSTEM		
ELECTRIC ENGINE OIL PRESSURE GAUGE		
NO OVERHEAD INSTRUMENT PANEL		
1 QUIKFIT PROGRAMABLE MODULE (QPM/XMC) W/ (4) 20AMP FUSED RELAYS	10	
AM/FM/WB WORLD TUNER RADIO WITH SIRIUSXM, BLUETOOTH, IPOD INTERFACE, USB AND AUXILIARY INPUTS, J1939		



Prepared For :  
 Craig Croner  
 GLENDALE CITY OF  
 6210 W MYRTLE AVE  
 GLENDALE, AZ 85301  
 UNITED STATES  
 Phone :623-930-2621

Prepared by:  
 Cory Thompson  
 FREIGHTLINER OF ARIZONA  
 9899 W ROOSEVELT STREET  
 TOLLESON, AZ 85353  
 Phone :

Description	Weight Front	Weight Rear
ROOF/OVERHEAD CONSOLE MOUNTED RADIO		
(2) RADIO SPEAKERS IN CAB		
NO AM/FM RADIO ANTENNA		
NO CB RADIO MOUNTING PROVISION		
SHARKFIN MULTI-BAND ANTENNA, RIGHT HAND BIAS ROOF MOUNTING LOCATION: AM/FM/WEATHERBAND, WIFI/BLUETOOTH, SDAR/SIRIUSXM, GNSS/GPS		
INTEROPERABLE SDAR ANTENNA		
STANDARD RADIO WIRING WITH STEERING WHEEL CONTROLS		
ELECTRONIC MPH SPEEDOMETER WITH SECONDARY KPH SCALE, WITHOUT ODOMETER		
STANDARD VEHICLE SPEED SENSOR		
ELECTRONIC 3000 RPM TACHOMETER		
DETROIT CONNECT PLATFORM HARDWARE		
3 YEARS DAIMLER CONNECTIVITY BASE PACKAGE ON (FEATURES VARY BY MODEL) POWERED BY DETROIT CONNECT ON CUMMINS ENGINES		
(2) TMC RP1226 ACCESSORY CONNECTORS: (1) LOCATED BEHIND PASSENGER SIDE REMOVEABLE DASH PANEL (1) CENTER OF BACKWALL/PASSENGER SIDE BAGGAGE COMPARTMENT		
IGNITION SWITCH CONTROLLED ENGINE STOP		
PRE-TRIP INSPECTION FEATURE FOR EXTERIOR LAMPS ONLY		
(1) OVERHEAD MOUNTED LANYARD CONTROL FOR DRIVER AIR HORN		
NO TRAILER HAND CONTROL BRAKE VALVE		
DIGITAL TURBO AIR PRESSURE IN DRIVER DISPLAY		
DIGITAL VOLTAGE DISPLAY INTEGRAL WITH DRIVER DISPLAY		
SINGLE ELECTRIC WINDSHIELD WIPER MOTOR WITH DELAY		
ROTARY HEADLAMP SWITCH, MARKER LIGHTS/HEADLIGHTS SWITCH WITH PULL OUT FOR OPTIONAL FOG/ROAD LAMPS		



Prepared For :  
 Craig Croner  
 GLENDALE CITY OF  
 6210 W MYRTLE AVE  
 GLENDALE, AZ 85301  
 UNITED STATES  
 Phone :623-930-2621

Prepared by:  
 Cory Thompson  
 FREIGHTLINER OF ARIZONA  
 9899 W ROOSEVELT STREET  
 TOLLESON, AZ 85353  
 Phone :

Description	Weight Front	Weight Rear
ONE VALVE PARKING BRAKE SYSTEM WITH WARNING INDICATOR		
SELF CANCELING TURN SIGNAL SWITCH WITH DIMMER, HEADLAMP FLASH, WASH/WIPE/INTERMITTENT		
INTEGRAL ELECTRONIC TURN SIGNAL FLASHER WITH 40 AMP (20 AMP PER SIDE) TRAILER LAMP CAPACITY		
NO WRG/SW-OPTL #2,CHAS,AIR		

**Design**

PAINT: ONE SOLID COLOR

**Color**

CAB COLOR A: L0006EY WHITE ELITE EY

BLACK, HIGH SOLIDS POLYURETHANE CHASSIS PAINT

SUNVISOR PAINTED SAME AS CAB COLOR A

STANDARD E COAT/UNDERCOATING

**Certification / Compliance**

U.S. FMVSS CERTIFICATION, EXCEPT SALES CABS AND GLIDER KITS

**Secondary Factory Options**

DEALER ACCEPTS RESPONSIBILITY FOR IN-SERVICE PDI INSPECTION

SHIP TO FONTAINE (MOUNT HOLLY, NC) PRIOR TO DELIVERY

**TOTAL VEHICLE SUMMARY**

**Weight Summary**

	Weight Front	Weight Rear	Total Weight
Factory Weight+	6676 lbs	3977 lbs	10653 lbs
Dealer Installed	0 lbs	0 lbs	0 lbs
<b>Total Weight+</b>	<b>6676 lbs</b>	<b>3977 lbs</b>	<b>10653 lbs</b>



Prepared For :  
 Craig Croner  
 GLENDALE CITY OF  
 6210 W MYRTLE AVE  
 GLENDALE, AZ 85301  
 UNITED STATES  
 Phone :623-930-2621

Prepared by:  
 Cory Thompson  
 FREIGHTLINER OF ARIZONA  
 9899 W ROOSEVELT STREET  
 TOLLESON, AZ 85353  
 Phone :

**Other Factory Charges**

CARB-COMPLIANT BASE WARRANTY DD5/DD8 SS/B6.7/L9 <=325  
 GHG24 SURCHARGE - CUMMINS  
 3 YEARS DAIMLER CONNECTIVITY BASE PACKAGE ON (FEATURES VARY BY MODEL) POWERED BY DETROIT CONNECT ON CUMMINS ENGINES  
 CUMMINS TARIFF CHARGE - \$205  
 STEEL, ALUMINUM, AND CHINA TARIFF IMPACT FEE 108/114 SD AND M2 106/112  
 MY26 ESCALATOR  
 STANDARD DESTINATION CHARGE

**Extended Warranty**

TOWING: 1 YEAR/UNLIMITED MILES/KM EXTENDED TOWING COVERAGE \$750 CAP FEX APPLIES

**Dealer Installed Options**

	Front Weight	Rear Weight
XBROOM SWEEPER BODY	0	0
XBROOM SWEEPER BODY	0	0
<b>Total Dealer Installed Options</b>	<b>0 lbs</b>	<b>0 lbs</b>

(+) Weights Shown are estimates only.  
 If weight is critical, contact Customer Application Engineering.

(\*\*) Prices shown do not include taxes, fees, etc... "Net Equipment Selling Price" is located on the Quotation Details Proposal Report.

(\*\*\*) All cost increases for major components (Engines, Transmissions, Axles, Front and Rear Tires) and government mandated requirements, tariffs, and raw material surcharges will be passed through and added to factory invoices.



Prepared For :  
 Craig Croner  
 GLENDALE CITY OF  
 6210 W MYRTLE AVE  
 GLENDALE, AZ 85301  
 UNITED STATES  
 Phone :623-930-2621

Prepared by:  
 Cory Thompson  
 FREIGHTLINER OF ARIZONA  
 9899 W ROOSEVELT STREET  
 TOLLESON, AZ 85353  
 Phone :

DIMENSIONS

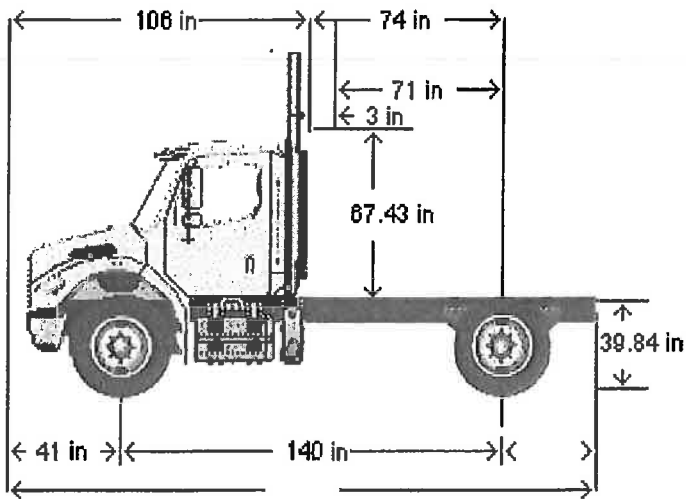

VEHICLE SPECIFICATIONS SUMMARY - DIMENSIONS

Model	M2106
Wheelbase (545)	3550MM (140 INCH) WHEELBASE
Rear Frame Overhang (552)	CUSTOM FRAME OVERHANG
Fifth Wheel (578)	NO FIFTH WHEEL
Mounting Location (577)	NO FIFTH WHEEL LOCATION
Maximum Forward Position (in)	0
Maximum Rearward Position (in)	0
Amount of Slide Travel (in)	0
Slide Increment (in)	0
Desired Slide Position (in)	0.0
Cab Size (829)	106 INCH BBC FLAT ROOF ALUMINUM CONVENTIONAL CAB
Sleeper (682)	NO SLEEPER BOX/SLEEPER CAB
Exhaust System (016)	RH OUTBOARD UNDER STEP MOUNTED HORIZONTAL AFTERTREATMENT SYSTEM ASSEMBLY WITH RH B-PILLAR MOUNTED VERTICAL TAILPIPE
Cab to Body Clearance (in)	3.0



Prepared For :  
 Craig Croner  
 GLENDALE CITY OF  
 6210 W MYRTLE AVE  
 GLENDALE, AZ 85301  
 UNITED STATES  
 Phone :623-930-2621

Prepared by:  
 Cory Thompson  
 FREIGHTLINER OF ARIZONA  
 9899 W ROOSEVELT STREET  
 TOLLESON, AZ 85353  
 Phone :

## TABLE SUMMARY - DIMENSIONS

Dimensions	Inches
Bumper to Back of Cab (BBC)	106.3
Bumper to Centerline of Front Axle (BA)	40.7
Front Axle to Back of Cab (AC)	65.6
Min. Cab to Body Clearance (CB)	3.0
Back of Cab to Centerline of Rear Axle(s) (CA)	74.2
Effective Back of Cab to Centerline of Rear Axle(s) (Effective CA)	71.2
Back of Cab Protrusions (Exhaust/Intake) (CP)	2.0
Back of Cab Protrusions (Side Extenders/Trim Tab) (CP)	0.0
Back of Cab Protrusions (CHG Tank)	0.0
Back of Cab Clearance (CL)	3.0
Back of Cab to End of Frame	-9.823.8
Cab Height (CH)	67.4
Wheelbase (WB)	139.8
Frame Overhang (OH)	-9.888.0
Overall Frame Length	-9.819.3
Overall Length (OAL)	-9.817.5
Rear Axle Spacing	0.0
Unladen Frame Height at Centerline of Rear Axle	39.8

Performance calculations are estimates only. If performance calculations are critical, please contact Customer Application Engineering.





Nescon, LLC.  
 4638 East Ingram St.  
 Mesa, Arizona 85205  
 Phone: 480-505-0001

THIS INVOICE CONTAINS CONFIDENTIAL INFORMATION THAT IS NOT TO BE SHARED WITH ANY PERSONS OTHER THAN THOSE DIRECTLY INVOLVED IN THE PURCHASE OF EQUIPMENT LISTED BELOW

Bill to:  
 City of Glendale  
 Public Works

JOB NAME: DanieleC

Job No: BRMXXXX

Ship to:  
 City of Glendale  
 Public Works

DATE: 9/5/2025

INVOICE NO:

lorn@tenape@mattinmarietta.com

Due: Upon Receipt

YES / NO Check	ITEM	QUANTITY	U.M.	SELL PRICE TOTAL	LIST PRICE TOTAL
X	2025/2026 Freightliner CDL/Non-CDL Model M2 PLUS / L9 Cummins 8.9L/300HP, 860TQ / Allison 3500 6SPD VNI: Equipped with X-Broom: SN: BRMXXXX *UPFIT ONLY*	1	Ea.	\$ 225,000.00	\$ 225,000.00
	Backup Camera - 1 Camera	1	Ea.	\$ 1,400.00	\$ -
X	Dual Camera - Hopper and Backup	1	Ea.	\$ 1,600.00	\$ 1,600.00
	Quad Camera System	1	Ea.	\$ 2,200.00	\$ -
X	Beacon, Wired to Top of Hopper, Includes Work Light In Hopper.	1	Ea.	\$ 750.00	\$ 750.00
X	Aluminum Wheels, 6 Polished Turbo.	1	Ea.	\$ 2,200.00	\$ 2,200.00
X	Chrome Heated Mirrors	1	Ea.	\$ 450.00	\$ 450.00
X	Chrome Front Bumper	1	Ea.	\$ 500.00	\$ 500.00
X	Power Windows/Door Locks	1	Ea.	\$ 450.00	\$ 450.00
X	Front Cab Visor	1	Ea.	\$ 400.00	\$ 400.00
X	Advanced Arrow, 25 LED 4" amber lights with separate controller. Can flash sequential Chevrons, arrows, alternating diamonds, and horizontal bar.	1	Ea.	\$ 2,700.00	\$ 2,700.00
	Optional Main Broom (TUBE/STRIP)	1	Ea.	\$ 2,600.00	\$ -
	Main Broom Down Pressure Option	1	Ea.	\$ 1,000.00	\$ -
	Stainless Hopper Bottom, Door	1	LS	\$ 11,100.00	\$ -
X	Work Lights on Top of Rear Panel	1	Ea.	\$ 400.00	\$ 400.00
X	Fill Hose Kit	1	Ea.	\$ 400.00	\$ 400.00
	Stainless Tool Box	1	Ea.	\$ 650.00	\$ -
	Door Controls (Broom and Hopper)	1	Ea.	\$ 1,000.00	\$ -
	25' Truck Washdown Kit	1	Ea.	\$ 300.00	\$ -
X	Light Package (8 Strobes, 1 Light Bar in Bumper)	1	Ea.	\$ 2,600.00	\$ 2,600.00
	Custom Color Option	1	Ea.	\$ 2,500.00	\$ -
X	Broom/Shovel Holder	1	Ea.	\$ 305.00	\$ 305.00
	Clear Lights (Arrow Board, Stop/Turn/Reverse, Marker)	1	Ea.	\$ 500.00	\$ -
X	Manual "On-The-Fly" Elevator Run/Off/Rev	1	Ea.	\$ 250.00	Included
X	Cab Controlled Variable Motor Speeds	1	Ea.	\$ 4,000.00	Included
	Poly Flights	1	Ea.	\$ 1,020.00	\$ -
	Piranha Brush Segments	1	Ea.	\$ 1,060.00	\$ -
	Pressure Washer/Hose	1	Ea.	\$ 4,000.00	\$ -
	Winterization Kit	1	Ea.	\$ 250.00	\$ -
	360 Light Package (52" Light Bars Mounted to Side Panels and Rear Arrow Board Panel)	1	Ea.	\$ 1,200.00	\$ -
	Hopper Dump Light	1	Ea.	\$ 400.00	\$ -
				Invoice Subtotal	\$ 237,755.00
X	FREIGHT (subject to change)	1	Ea.	\$ -	\$ -
	DEPOSIT	-1	Ea.	\$ 10,000.00	\$ -
	30 DAY TEMP TAG	1	Ea.	\$ 50.00	\$ -
X	DEALER DOC FEE	1	Ea.	\$ 250.00	\$ 250.00
	ESTIMATED DELIVERY: 30-60 DAYS *PM-10 COMPLIANT*			Invoice Total:	\$ 238,005.00
	**\$10,000 deposit required to hold build slot*				
	*Any applicable sales tax is the responsibility of the purchaser*				
	*BROOM PRICING PROVIDED IS SUBJECT TO RAW MATERIAL, DELIVERY, AND MAJOR COMPONENT COST INCREASES AS ANNOUNCED BY NESCON, LLC AND/OR THEIR SUPPLIERS*				
	<u>Wiring Instructions</u>				
Bank:	JP Morgan Chase 2104 E Elliott Rd Tempe, AZ 85284				
Contact:	Nicolas Deleo, 480-963-2791				
ABA Routing no:	021000021				
Ind SWIFT code:	CHASUS33				
Account Name:	Nescon, LLC.				
Accl Number:	949565998				
	Received By:			Date:	

May 19, 2017

**EXAMPLES OF ADDITIONAL STREET SWEEPER EQUIPMENT  
NOT ELIGIBLE FOR REIMBURSEMENT**

1. Automatic lubrication system  
(Autolube, grease jockey system)
2. Hopper access step
3. Hydrant hopper wash down system  
STANDARD
4. Conveyer flush kit with hydrant
5. 1000 pounds per square inch (PSI) wand
6. Dual HiBack air-suspended seats  
\$422
7. Hand hose
8. Hopper sound suppression
9. Right hand steer chassis upcharge  
\$20,000
10. Air horn (reimbursable when  
conventional electric horn is not  
included)  
\$82
11. AM/FM radio; CD  
STANDARD
12. Training  
STANDARD
13. Magnet bar
14. Stainless steel hopper
15. Sweeper, truck and wheel yellow paint
16. Additional roof-mounted air  
conditioner  
\$10,000
17. Holder rear mount for five-gallon pail
18. Cigarette lighter with 12v
19. Foam filled tire
20. Window tinting
21. Move exhaust port to left side of vehicle
22. John Deere auxiliary engine - Tier iT4



# RESIDENTIAL STREET SWEEPING SCHEDULE

Residential sweeping of the City is completed MONTHLY which includes collector streets. Dates are listed below for each colored section to follow closely behind bulk trash collection.



- JAN 8-15
- FEB 5-12
- MAR 5-12
- APR 9-16
- MAY 7-14
- JUNE 4-11
- JULY 9-16
- AUG 6-13
- SEPT 3-10
- OCT 8-15
- NOV 5-12
- DEC 3-10



- JAN 15-22
- FEB 12-19
- MAR 12-19
- APR 16-23
- MAY 14-21
- JUNE 11-18
- JULY 16-23
- AUG 13-20
- SEPT 10-17
- OCT 15-22
- NOV 12-19
- DEC 10-17



- JAN 22-29
- FEB 19-26
- MAR 19-26
- APR 23-30
- MAY 21-28
- JUNE 18-25
- JULY 23-30
- AUG 20-27
- SEPT 17-24
- OCT 22-29
- NOV 19-26
- DEC 17-24



- JAN 29 - FEB 5
- FEB 26 - MAR 5
- MAR 26 - APR 2
- APR 30 - MAY 7
- MAY 28 - JUNE 4
- JUNE 25 - JULY 2
- JULY 30 - AUG 6
- AUG 27 - SEPT 3
- SEPT 24 - OCT 1
- OCT 29 - NOV 5
- NOV 26 - DEC 3
- DEC 24 - DEC 31

